



# ROLS24-W

## Remote Optical Laser Sensor



### SAFEGUARDS AND PRECAUTIONS:



**WARNING** – Class 2 laser product – This product emits a visible beam of laser light. Avoid exposure to the laser radiation. The use of optical viewing aids (binoculars, for example) may increase the ocular hazard.

**CAUTION** – The laser beam should not be intentionally aimed at people or animals.



**CAUTION** – Use of controls or adjustments or performance of procedures other than those specified herein may result in hazardous radiation exposure.

Read and follow all instructions in this instruction sheet carefully, and retain this sheet for future reference. Do not use this instrument in any manner inconsistent with these operating instructions or under any conditions that exceed the environmental specifications stated.

This instrument is not user serviceable. For technical assistance, contact the sales organization from which you purchased the product.



### DESCRIPTION:

The Remote Optical Laser Sensor has a visible red laser light source and green LED on-target indicator. The class 2 laser source acts as the aiming device during setup and can accurately measure speeds from 1-250,000 RPM from a distance of up to 25 feet with a maximum offset angle of 60 degrees from the rotating object. The sensor is housed in a threaded 303 stainless steel tube and supplied with a 90 degree mounting bracket, jam nuts and an eight foot shielded cable. **ROLS24-W** comes with 4 tinned wires.



### SPECIFICATIONS:

- Speed Range:** 1-250,000 RPM
- Illumination:** Visible Red Laser, Class 2
- Laser Specifications:**
  - Classification:** Class 2 (per IEC 60825-1 Ed 1.2 2001-8)
  - Complies with FDA performance standards for laser products except for deviations pursuant to Laser Notice No. 50, dated July 26, 2001.
  - Maximum Laser Output:** 1mW
  - Pulse Duration:** Continuous
  - Laser Wavelength:** 650 nm
  - Beam Divergence:** <1.5 mrad
  - Beam Diameter:** 4 x 7 mm typical at 2 meters
  - Laser Diode Life:** 8,000 operating hours MTBF (1 year warranty)
- On-Target Indicator:** Green LED on wire end cap
- Operating Range:** up to 25 feet [7.6 m] and 60 degrees offset from target
- Power Requirement:** 9 - 24 Vdc, 0.13W
- Output:** Positive pulse when target present – Output Voltage=Supply Voltage  
Optional – Open Collector or TTL pulse, Negative pulse (Contact factory)
- Operating Temp.:** 14 °F to 158° F [-10 °C to 70° C]
- Humidity:** Maximum relative humidity 80% for temperature up to 88 °F [31 °C] decreasing linearly to 50% relative humidity at 104 °F [40 °C]
- Connection:** Tinned wires
- Cable Length:** 8 feet [2.4 m]
- Material:** 303 Stainless Steel supplied with two M18 Jam Nuts and Mounting Bracket
- Lens:** Acrylic Plastic
- Dimensions:** Threaded Tube 3.12 in x 0.71 in diameter [M18 x 1.5 x 79.4 mm] long

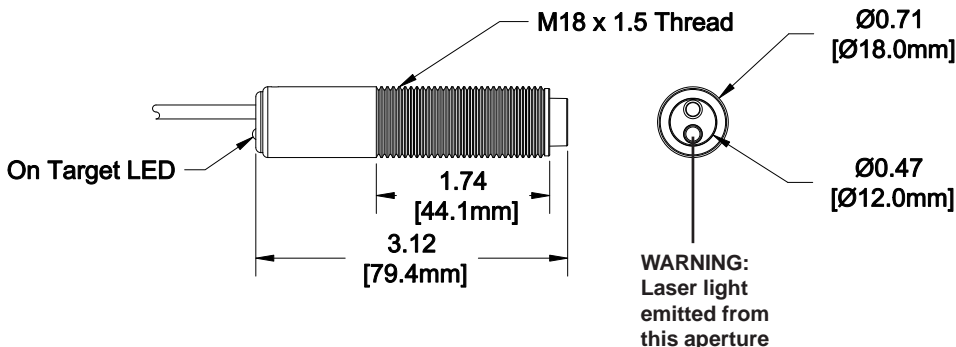

## CONNECTION DETAIL for ROLS24-W:

<u>Wire Color</u>	<u>Function</u>	
Brown	Positive Power Supply	(12 to 24 Vdc)
Blue	Common	(Com)
Black	Signal (+V to 0 Vdc Pulse)	(Sig)
Shield	Housing Ground	(Com)

### OPERATING INSTRUCTIONS:

The ROLS24-W Remote Optical Laser Sensor is capable of detecting a reflected pulse from a target consisting of T-5 Reflective Tape or high contrast color differences (such as black and white) at distances up to 25 feet [7.6 m] from the rotating object and angles up to 60 degrees. For most applications, a ½" [12 mm] square piece of Reflective Tape (T-5) should be applied to a clean area on the rotating object. At slow speeds (<500 RPM) best results will be obtained by aiming the laser perpendicular (90°) to the target using a narrow piece of reflective tape – typically 0.2 inch (5 mm) wide.

The ROLS24-W should be mounted (using the supplied jam nuts and aluminum mounting bracket) and optically aligned to illuminate the on-target indicator once per revolution. It is recommended that the optical sensor be placed at a slight angle (15 degrees) from perpendicular, so that the sensor will receive only pulses from the reflective marker. Triggering from contrasting colors should be done perpendicular to the target. The ROLS24-W should be at least 1 inch from the reflective target to avoid false triggering. The green LED On-Target Indicator will blink at the input frequency rate when the ROLS24-W is properly aimed. **NOTE:** The green LED On-Target Indicator will blink on and off at slow speeds and remain on steady at high speeds.

The ROLS24-W is supplied with an 8 foot [2.4 m] cable terminated with 4 tinned wires.

The ROLS24-W will work with all Monarch panel instruments that accept pulse inputs (e.g. ACT Series, DataChart 1250, DataChart 6000) and vibration data collectors.

### ACCESSORIES:

T-5	Reflective Tape - 5 foot [1.5 m] roll
T-5WP	Waterproof Reflective Tape - 5 foot [1.5 m] roll
ROLS-NUT	Set of two M18 Jam Nuts
ROLS-MNT	90° Slotted Mounting Bracket
PLUG	3.5 mm [1/8 inch] male stereo plug
WIRE	3-wire shielded Sensor Cable, bulk lengths



#### In order to comply with EU Directive 2002/96/EC on Waste Electrical and Electronic Equipment (WEEE):

This product may contain material which could be hazardous to human health and the environment. DO NOT DISPOSE of this product as unsorted municipal waste. This product needs to be RECYCLED in accordance with local regulations, contact your local authorities for more information. This product may be returnable to your distributor for recycling - contact the distributor for details.

CE Compliant. RoHS Compliant. Meets the safety requirements of IEC61010-1 and IEC60825-1.

Monarch Instrument's Limited Warranty applies. See [www.monarchinstrument.com](http://www.monarchinstrument.com) for details.

Warranty Registration and Extended Warranty coverage available online at [www.monarchinstrument.com](http://www.monarchinstrument.com).

**Monarch Instrument**  
15 Columbia Drive  
Amherst, NH 03031 USA  
Phone: (603) 883-3390  
Fax: (603) 886-3300  
E-mail: [support@monarchinstrument.com](mailto:support@monarchinstrument.com)  
Website: [www.monarchinstrument.com](http://www.monarchinstrument.com)

**1071-4849-110R**

0711