



MONARCH INSTRUMENT

Instruction Manual



Monarch 311 Humidity Temperature Meter

15 Columbia Drive
Amherst, NH 03031-2334 USA
Phone: (603) 883-3390
Fax: (603) 886-3300
E-mail: support@monarchinstrument.com
Website: www.monarchinstrument.com

© Monarch Instrument 2002 all rights reserved

1071-8041-110



Safeguards and Precautions



- 1. Read and follow all instructions in this manual carefully, and retain this manual for future reference.**
- 2. Do not use this instrument in any manner inconsistent with these operating instructions or under any conditions that exceed the environmental specifications stated.**
- 3. Do not touch or manipulate the sensor.**
- 4. Do not expose the sensor to direct light. This may cause false readings.**
- 5. Do not expose the sensor to static electricity.**
- 6. Making measurements of high or low temperature can be dangerous. Keep the hand holding the temperature probe well away from the object being measured.**
- 7. This instrument is not user serviceable. For technical assistance, contact the sales organization from which you purchased the product or Monarch Instrument directly.**

LIMITED WARRANTY

SELLER warrants hardware products to be free from any defect in materials or workmanship for a period of one (1) year from date of shipment to BUYER. SELLER's entire liability and BUYER's sole and exclusive remedy resulting from any defect in workmanship or material in the hardware product covered by this limited warranty shall be limited to and fully discharged by the SELLER's option of replacement or repair of such item without charge. The limited warranty provided in this clause is in lieu of all other warranties, expressed or implied, arising by law or otherwise. ALL IMPLIED WARRANTIES OF MERCHANTABILITY AND FITNESS FOR A PARTICULAR PURPOSE ARE EXCLUDED. This limited warranty shall not be modified except by an arrangement signed by both parties specifically referencing this clause.

SELLER warrants that any software supplied will operate in accordance with the documentation or manual supplied therewith in all material respects when used in strict compliance with such documentation or manual. Notwithstanding the foregoing, BUYER acknowledges that, since software is complex and therefore may have defects, BUYER's sole and exclusive remedy for any such defects or breach of this warranty shall be to require SELLER, within a reasonable period of time, to provide all reasonable programming services to correct programming errors in the software. Except as provided above SELLER MAKES AND BUYER RECEIVES FROM SELLER NO EXPRESS OR IMPLIED WARRANTIES OF ANY KIND WITH RESPECT TO ALL OR ANY PORTION OF SOFTWARE AND BUYER HEREBY AGREES AND ACKNOWLEDGES THAT IT ACCEPTS THE SOFTWARE IN 'AS IS' CONDITION. SELLER HEREBY EXPRESSLY EXCLUDES ANY IMPLIED WARRANTIES OF MERCHANTABILITY OR FITNESS FOR A PARTICULAR PURPOSE WITH RESPECT TO THE SOFTWARE. BUYER agrees that any specific right or remedy granted to BUYER hereunder with respect to any breach or default by SELLER shall be in lieu of all other rights and remedies otherwise available to BUYER at law or in equity as the result of such breach or default, regardless of whether based on contract, tort, strict liability, or other theory of liability.

IN NO EVENT SHALL SELLER BE LIABLE FOR ANY SPECIAL, INDIRECT, INCIDENTAL, CONSEQUENTIAL, OR PUNITIVE LOSSES OR DAMAGES (INCLUDING, BUT NOT LIMITED TO, LOSSES OR DAMAGES FOR ANY LOST PROFITS OR LOST DATA) AS THE RESULT OF ANY BREACH OR DEFAULT BY SELLER WITH RESPECT TO THE HARDWARE OR SOFTWARE, EVEN IF SELLER HAS BEEN ADVISED OR MADE AWARE OF THE POSSIBILITY OF ANY SUCH LOSSES OR DAMAGES AND REGARDLESS OF WHETHER THE CLAIM IS BASED ON CONTRACT, TORT, STRICT LIABILITY, OR OTHER THEORY OF LIABILITY.

This limited warranty does not extend or apply to consumables (including, but not limited to, lamps and batteries, if applicable) or equipment, instruments or accessories which are warranted separately by the original manufacturer of these items.

DECLARATION OF CONFORMITY

Monarch Instrument
 Division of Monarch International Inc.
 15 Columbia Drive, Amherst NH 03031 USA

declares that the product:

Name: Humidity Temperature Meter
Model: Monarch 311

to which this declaration relates is in conformity with the following standards:

EMC: EN55011/1991
 EN50081-1/1992
 EN50082-1/1992 / IEC 801

and therefore conforms in accordance with 89/336/EEC-EMC Directive. The testing of this product was performed by GesTek EMC Lab. in January of 2000. (Ref. No. 99C049E).

2nd February 2000
 Importer (Amherst, NH)



Alan Woolfson, VP Engineering (Authorized Signature)

Table of Contents

Section	Page
1.0 Introduction	1
2.0 Specifications	1
3.0 Symbol Definitions and Feature Locations	2
4.0 Operating Instructions	3
4.1 Preparation for Measurement	3
4.2 Power	3
4.3 Humidity and Temperature (T1) Measurement	3
4.4 Selecting the Temperature Scale	3
4.5 Data-Hold Operation	3
4.6 Relative Operation	3
4.7 MAX/MIN Operation	3
4.8 Auto Power Off	3
4.9 Low Battery Condition	3
4.10 Digital Output	3
Appendix: Thermocouple Probe Specifications	4
5.0 Calibration Procedure	4
5.1 Humidity Calibration	4
5.2 T1 Temperature Calibration	4
5.3 Notes on Humidity and Temperature Calibration	5

1.0 Introduction:

This instrument is a dual channel digital Humidity/Temperature meter providing simultaneous display of ambient humidity and temperature on the first channel, and a wide range temperature only measurement on the second channel. The first channel incorporates a polymer capacitive humidity sensor and a semiconductor temperature sensor (T1) in a detachable probe. The second channel employs a Type K thermocouple that complies with the NIST and IEC584 temperature/voltage tables for Type K thermocouples. The instrument is equipped with a RS232 interface for bi-directional communication with a PC.

2.0 Specifications:

Measurement Range: Humidity: 0% - 100%RH
 Temperature: T1: -20°C - +60°C, -4°F - +140°F
 T2: -200°C - +1370°C, -328°F - +2498°F

Accuracy: Humidity: ±2.5% RH at 25°C
 Temperature: T1: ±0.7°C, ±1.4°F
 T2: See table below.

at (23 ± 5°C)

Range	Accuracy
-200°C - 200°C	±(0.3% reading + 1°C)
200°C - 400°C	±(0.5% reading + 1°C)
400°C - 1370°C	±(0.3% reading + 1°C)
-328°F - -200°F	±(0.5% reading + 2°F)
-200°F - 2498°F	±(0.3% reading + 2°F)

Temperature Coefficient:

For ambient temperatures from 0°C -18°C and 28°C - 50°C, for each °C ambient below 18°C or above 28°C add the following tolerance into the accuracy spec.

0.01% of reading + 0.03°C
 (0.01% of reading + 0.06°F)

▲ Note:

The basic accuracy specification does not include the error of the probe. Please refer to the probe accuracy specification for additional details.

Resolution: Humidity: 0.1%RH
 Temperature: T1: 0.1°C, 0.1°F
 T2: -200°C - 200°C: 0.1°C; 200°C -1370°C: 1°C
 -200°F - 200°F: 0.1°F; beyond this range: 1°F

Sensor Inputs: Channel 1: Detachable probe with humidity and temperature (T1) sensors
 Channel 2: Type K Thermocouple (T2)

Input Protection at Thermocouple Input (T2): 60V DC, or 24Vrms AC

Display: Triple 4 Digit Display plus Indicators, see Section 3.0

Response Time: Humidity: 75 seconds in slowly moving air
 Temperature: 40 seconds in slowly moving air (T1)

Digital Output: Bi-directional RS232

Power requirement: 9 Volt Battery, NEDA 1604 or JIS 006P or IEC6F22

Battery Life: Approx. 100 hours with alkaline battery. Low battery indication

Operating Conditions:

- Operating Temperature and Humidity: 0°C - 50°C (32°F - 122°F); 0 - 90% RH Non-condensing
- Storage Temperature and Humidity: -10°C - 60°C (14°F - 140°F); 0 - 80% RH Non-condensing
- Altitude up to 2000 meters (6500 feet)

Dimensions: Meter = 186×64×30 mm (7.3×2.5×1.2 inches)
 Probe = 190 mm long×15 mm diameter (7.5×0.6 in)

Weight: Approx. 320g (10.8 oz)

Accessories: Type K Wire Thermocouple Probe, Battery, Carrying Case, Humidity Probe Holder, Instruction Manual

Options: AC Adapter: 9VDC ±15%, 100mA; Plug Diameter: 3.5mm×1.35mm
 Software and RS232 cable

- Insert the probe into a temperature-controlled chamber at 40°C (104°F) and again allow the system to stabilize for 20 minutes. Press the **MAX MIN** button to create the calibration data. If the instrument recognizes the value is out of tolerance, it will sound 2 beeps and remain in the 'CAL2' mode. If the instrument recognizes the value is within tolerance, new calibration data will be written into the memory and the calibration is complete.

5.3 Notes on Humidity and Temperature Calibrations

- While performing the humidity calibration, the environment should be maintained at stable conditions (i.e. constant temperature and constant humidity) to optimize the accuracy.
- During either calibration, pressing the **ON/OFF** button at any time will return the instrument to the normal operating mode, and no calibration data will be changed.
- To restore factory default calibration values, press the **HOLD** and **°C** buttons simultaneously at any time while in the calibration mode.
- Whenever the probe is inserted into a standard humidity cavity or temperature-controlled chamber, always allow at least 20 minutes to ensure ambient conditions have stabilized.
- Always begin the humidity calibration process with the 32.8% RH@25°C standard cavity and the temperature calibration process with the 0°C (32°F) temperature-controlled chamber. For maximum efficiency, insert the probe into the conditioned environment 20 minutes before applying power to the instrument and starting the calibration process.
- During the calibration, all displayed readings are based on pre-process calibration data.
- The 'Auto Power Off' function is disabled during calibration, but is automatically restored upon completion.
- During the calibration, the temperature is fixed on the °F scale and it is not selectable.

3.0 Symbol Definitions and Feature Locations:

- : Low battery indication. Battery voltage is not sufficient for proper operation.
- : Indicates 'Auto Power Off' is enabled
- : Indicates that the display data is being held
- ΔREL** : The Relative value is now being displayed
- MAX** : The Maximum value is now being displayed
- MIN** : The Minimum value is now being displayed
- y** : Indicates year is displayed in the main window
- K** : Thermocouple type indication
- %RH** : Relative Humidity indication
- m-d** : Indicates the value below is month and day
- T1 T2** : Indicates which temperature channel is being displayed
- h:m** : Indicates the value below is hour and minute
- m:s** : Indicates the value below is minute and second
- : Negative temperature indication
- °C°F** : Centigrade or Fahrenheit indication

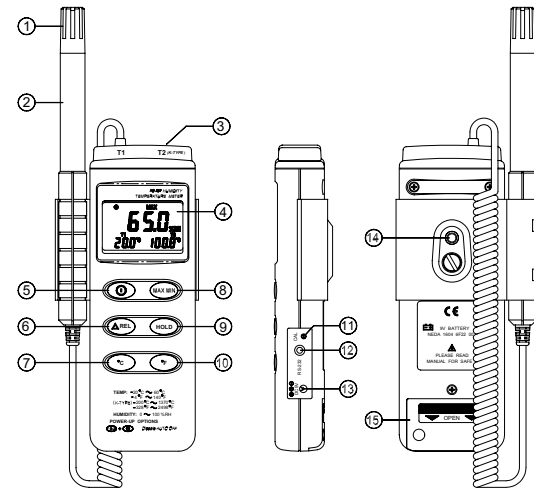
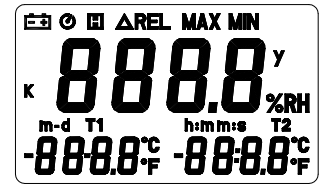

- Feature Locations:**
- Dust mask
 - Sensor probe
 - T2 channel, Type K thermocouple probe input
 - LCD display
 - ON/OFF button
 - Relative readout button
 - °C control button
 - MAX MIN function control button
 - HOLD button
 - °F control button
 - Type K offset calibration screw
 - Digital output connector (RS232)
 - AC power adapter connector
 - Tripod connector
 - Battery cabinet cover

4.0 Operating Instructions:

4.1 Preparation for Measurement

Measurement of ambient humidity and temperature (T1) may be made with the probe clipped to the instrument or hand held remotely. For measurement of a second temperature, plug a Type K thermocouple into the socket marked **T2**, taking care to observe the polarity of the thermocouple pins.

4.2 Power

Press the **⏻** button to turn the thermometer ON or OFF.

4.3 Humidity and Temperature (T1) Measurement

Place the humidity temperature probe in the environment to be measured. Be sure to allow sufficient time for the sensors to respond to ambient conditions. This time will be dependent on the amount of air circulation through the probe mask. (See Section 2.0: Response Time.)

4.4 Selecting the Temperature Scale

When first turned on, the instrument defaults to reading in Celsius (°C). To display readings in Fahrenheit (°F), press the **°F** button. To return to readings in Celsius (°C), press the **°C** button. The instrument remembers the scale setting when last turned off and powers on in that setting the next time.

4.5 Data-Hold Function

The present reading is held on the display by pressing the **HOLD** button. Pressing the **HOLD** button again releases the hold function and returns the instrument to continuous reading.

In the **HOLD** mode, the **MAX MIN**, **°C**, **°F** and **ΔREL** buttons are disabled, as indicated by two consecutive beeps when pressed.

4.6 Relative Operation

Pressing the **ΔREL** button zeroes the display and internally stores the present reading as a reference for subsequent measurements. The main display now shows the difference between the stored value and the new reading. Press the **ΔREL** button again to exit the Relative mode.

In the Relative Operation mode, the **°C**, **°F** buttons are disabled, as indicated by two consecutive beeps if pressed.

4.7 MAX/MIN Operation

Press the **MAX MIN** button to enter the MAX/MIN mode. In this mode, both the maximum and minimum values are simultaneously retained in memory and updated with every new data sample. The instrument first enters the MAX mode, and the MAX symbol and value are both displayed. Pressing **MAX MIN** again advances the display to the MIN symbol and value. The next press of the **MAX MIN** button will cause both the MAX and MIN symbols to flash. This indicates that the maximum and minimum values have been updated in memory and the displayed reading is the present value. Each successive press of the **MAX MIN** button circulates the display mode among these options. To exit the MAX/MIN mode, press and hold **MAX MIN** for two seconds.

In the MAX/MIN mode, the **°C**, **°F** and **ΔREL** buttons are disabled, as indicated by two consecutive beeps if pressed.

4.8 Auto Power Off

By default, the instrument powers on in the 'Auto Power Off' mode and will automatically shut off 30 minutes after the last key operation or RS232 communication.

To disable this feature, press and hold the **HOLD** button and then power on the meter. Two successive beeps will indicate that 'Auto Power Off' is disabled, and the **⏻** will not be displayed.

4.9 Low Battery Condition

When the battery voltage is at or below the minimum for proper operation, the **⚡** symbol will show on the display indicating that the battery must be replaced.

4.10 Digital Output

The Digital Output is a 9600 bps N 81 serial interface.

RX is a 5V normally high input port.

TX is a 5V normally high output port.

WARNING!

1. Do not touch or manipulate the sensor.
2. Do not expose the sensor to direct light. This may cause false readings.
3. Do not expose the sensor to static electricity.

Appendix: Thermocouple Probe Specifications

Model	Range	Tolerances	Description
TP-K01	-50°C to 200°C	±2.2°C or ±0.75%	Teflon insulation. Maximum insulation temperature: 260°C (500°F)
Wire probe	-58°F to 392°F	±3.6°F or ±0.75%	

TP-K01:

Probe for general condition measurements, especially for complex and hard to reach places.

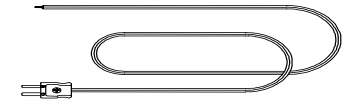

5.0 Calibration Procedure

5.1 Humidity Calibration

1. Turn the unit off. Press and hold the **MAX MIN**, **HOLD** and **°C** buttons. While these three buttons are pressed, turn the power on. Release these buttons and all the segments on the display will flash.
2. Within 3 seconds of releasing these buttons, press the **°F** and **REL** buttons simultaneously to enter the calibration mode, or the instrument will revert to the normal operating mode.
3. Upon entering the calibration mode, the humidity reading will flash, and 'CAL1' will appear on the second display.
4. Insert the humidity probe into the standard humidity cavity of 32.8% RH@25°C. Allow the system to stabilize for 20 minutes, and then press the **MAX MIN** button to create the calibration data. If the instrument recognizes the value is out of tolerance, it will sound 2 beeps and remain in the 'CAL1' mode. If the instrument recognizes the value is within tolerance, new calibration data is created and the instrument will advance into the 'CAL2' mode, as indicated on the second display.
5. Insert the humidity probe into the standard humidity cavity of 75.3% RH@25°C. Again allow the system to stabilize for 20 minutes, and then press the **MAX MIN** button to create the calibration data. If the instrument recognizes the value is out of tolerance, it will sound 2 beeps and remain in the 'CAL2' mode. If the instrument recognizes the value is within tolerance, new calibration data will be written into the memory and the calibration is complete.

5.2 T1 Temperature Calibration

1. Turn the unit off. Press and hold the **MAX MIN**, **HOLD** and **°C** buttons. While these three buttons are pressed, turn the power on. Release these buttons and all the segments on the display will flash.
2. Within 3 seconds of releasing these buttons, press the **°F** and **HOLD** buttons simultaneously to enter the calibration mode, or the instrument will revert to normal operating mode.
3. Upon entering the calibration mode, the temperature reading will flash and 'CAL1' will appear on the second display.
4. Insert the probe into a temperature-controlled chamber at 0°C (32°F) and allow the system to stabilize for 20 minutes. Press the **MAX MIN** button to create the calibration data. If the instrument recognizes the value is out of tolerance, it will sound 2 beeps and remain in the 'CAL1' mode. If the instrument recognizes the value is within tolerance, new calibration data is created and the instrument will advance into the 'CAL2' mode, as indicated on the second display.