

PowerLine Magnetic-Laser Pulley Alignment System Instructions

The **PowerLine Magnetic-Laser Pulley Alignment System** laser aligns belts, pulleys, sheaves, sprockets, gear trains, rollers, platforms, conveyors, and other plant equipment. Its purpose is to replace often time's inaccurate and time-consuming straightedge and string alignment methods currently in use. Compared to these older methods, PowerLine is easier, faster, and more accurate. With PowerLine, you will greatly reduce downtime and belt failures.

Component Descriptions

The **PowerLine Magnetic-Laser Pulley Alignment System** includes a laser line emitter, three grooved targets, and 2 belt tension testers. All components are especially rugged for long life and are shipped in a sturdy storage case.



Laser Line Emitter

Its bottom machined surface mounts magnetically to the machined face of pulley, sheave, gear, etc. It projects a 1/16" thick laser reference line over a wide angle. The projected reference line is parallel to the machined bottom surface and offset from it by 0.312".

Laser Safety
 Caution
 Use of controls or adjustments or performance of procedures other than those specified herein may result in hazardous radiation exposure.

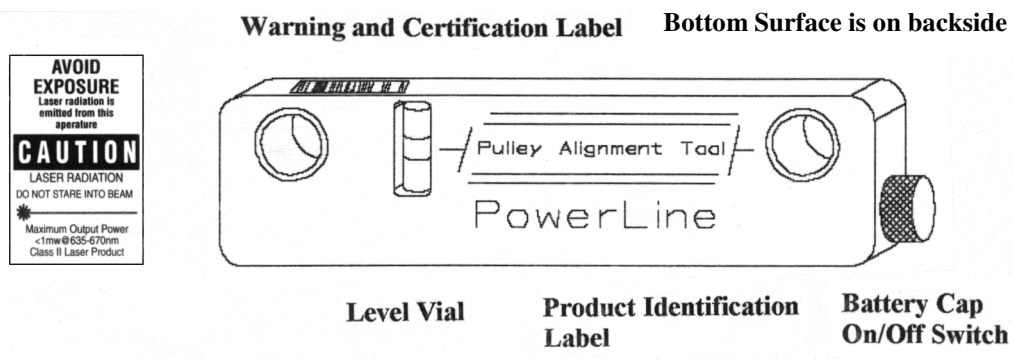

The PowerLine line emitter uses a laser diode with a maximum output power of less than <1 milliwatt @ 635 nm. The laser classification is a Class II with only minor precautions required. Never stare directly into laser transmitter or aim laser into someone's eyes. PowerLine complies with 21CFR parts 1040.10 and 1040.11.

Grooved Targets

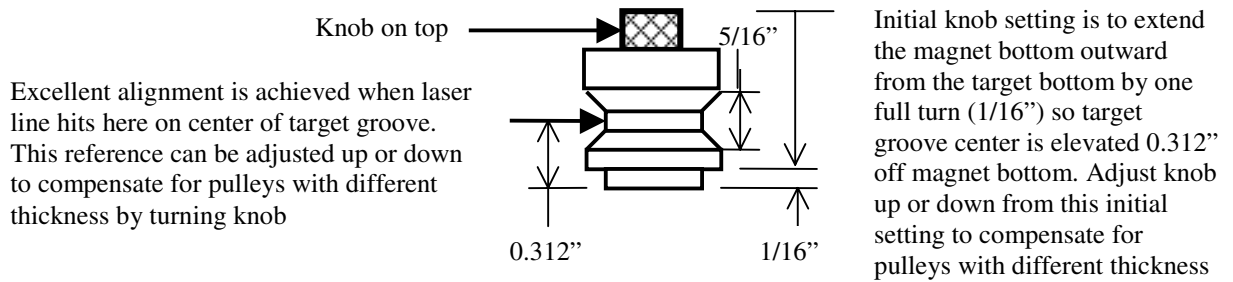

Three cylindrical grooved targets mount magnetically to the machined face of the pulley, sheave, gear, etc. opposite the line laser. The targets track the position of the machined face relative to the laser reference line emitted by the PowerLine laser. Excellent alignment is achieved when the laser line strikes the center of the cylindrical grooves on all three targets simultaneously. Note, as a visual aid, when the laser strikes the target center, it gives a brighter reflection than when laser strikes the V shaped sides.

The offset between the center of the target groove and the magnetic bottom of the target is adjustable to compensate for differences in pulley endwall thickness, belt wear, and groove wear. Turn the knurled knob on the top of the target to make adjustments either up or down. As marked on top, one full turn of the knob moves the target center up or down 1/16". The initial knob setting is to extend the magnet bottom outward from the bottom of the target bottom by one full turn (1/16" extended) so that the target center is 0.312" away from the magnetic bottom. (See sketch on previous page.) For example, it is very common to find pulleys of smaller diameter to have thinner rims than pulleys of larger diameter. During setup, measure this difference using a dial caliper or equal means. Prior to mounting the targets, adjust the knobs of all three targets to compensate for the measured difference. When the laser is on the smaller pulley, the offset will be reduced from initial setting of 0.312 by turning knob CCW.

PowerLine Laser Pulley Alignment Tool Alignment and Tensioning Procedure

1. Prerequisites

Caution:

Lock out and tag out equipment before you start work.
Follow all applicable plant procedures.

- Inspect machinery bases and foundation for deterioration, looseness, and cracking.
- Check all base bolts for correct torque and eliminate any soft foot conditions.
- Remove belt guards as needed for access.
- Check pulleys and belts for wear. Replace as necessary.
- Check each shaft's runout with a dial indicator. Excessive runout implies shaft or bearing problems.
- Check pulley side wobble and runout with a dial indicator. Stay within pulley manufacturer guidelines.
- Install V-belts onto pulleys.

2. Compensate For Pulley Endwall Thickness Difference and Mount Laser and Targets

Using an inside caliper, measure the difference in endwall thickness between the two pulleys being aligned. The measurement can be easily taken using the depth gauge end of the caliper. Place the butt end of the caliper against the machined side face of the pulley and extend out the depth micrometer end of the caliper until it contacts the side of the V-belt. Measure each pulley. If the difference is larger than 1/64", then compensate for it using the targets, as explained in **Grooved Targets** section above.

Mount the PowerLine Laser and targets as figured below. Note that the laser emitter can mount either on the small pulley or the large pulley based on field conditions, however, it is preferable that to mount it on the smaller diameter of the belt. Point the laser line so it projects along the tight side of the belt towards the companion pulley. Mount the three targets on the companion pulley at the 12, 9, and 6 o'clock positions as shown. Make sure each target's magnetic bottom is extended full turn (1/16") from flush thickness, or, if you are compensating for pulley endwall make sure your adjustment is done equally on all three

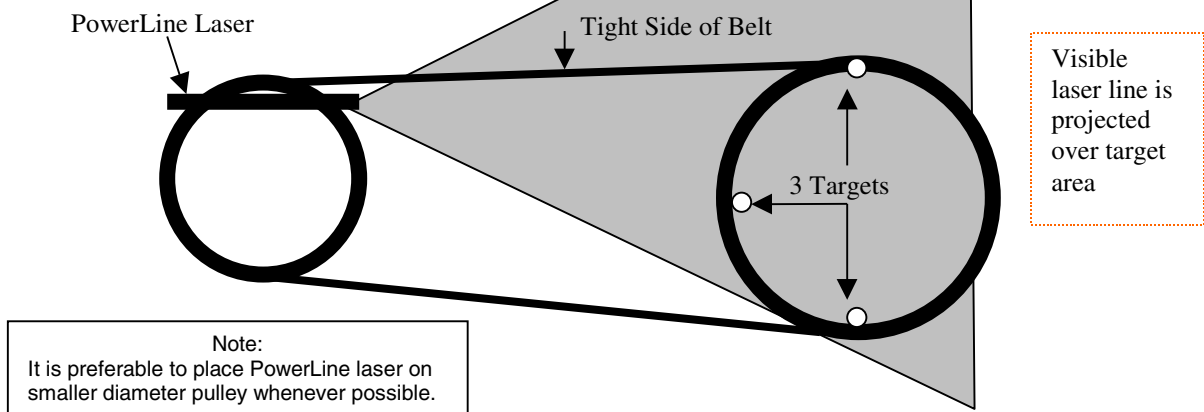

3. Turning the PowerLine Laser on and off

Turn on the PowerLine laser by rotating the battery compartment end cap clockwise until the battery circuit is energized. To turn off the laser, rotate the end cap counterclockwise and back off one full turn. This will ensure laser does not energize inadvertently in storage. Spare batteries are included in the case.

4. Align Equipment Using Laser Targets

Align equipment until the projected laser line strikes the center of the groove on all three targets simultaneously. This indicates excellent alignment. If the targets are not "aligned", then the procedure for correcting any misalignment is as follows:

The misalignment visible between the 12 o'clock and 6 o'clock targets indicates amount of "vertical" angular and parallel misalignment. To correct this misalignment, loosen, shim, and tighten base bolts and/or adjust pulley axial positions on their respective shafts until "vertical" misalignment is corrected. The laser line should now strike the target center of both the 12 o'clock and 6 o'clock targets.

The misalignment visible between the 12 o'clock and 6 o'clock targets and the 9 o'clock target indicates amount of "horizontal" misalignment. To correct, move the 6 o'clock target to 3 o'clock. Adjust the position of the front and/or back feet of one or both of the machines horizontally to correct for horizontal misalignment until the laser line strikes the target centers of both the 3 o'clock and 9 o'clock targets simultaneously. Verify your also hitting center of 12 o'clock target. Remember to test and adjust for proper belt tension while aligning. After adjustment, the laser line should now strike the bottom of the groove of all three targets, indicating excellent alignment.

User has option to turn pulleys every 90 degrees and check laser and targets. They should still show excellent alignment as long as the alignment prerequisites were met, especially shaft runout and pulley wobble.

Restore equipment to normal.

5. Belt Alignment Tolerances

Per Gates Rubber Company, a prominent V-belt manufacturer, good alignment tolerance is as follows:

- V-belt drive sheave alignment should be less than $\frac{1}{2}^\circ$ or $\frac{1}{10}$ " per foot of drive center distance after tensioning.
- Synchronous, Polyflex® and Micro-V® belts should be within $\frac{1}{4}^\circ$ or $\frac{1}{16}$ " per foot of driver center distance. Using the PowerLine laser and targets and following the correct alignment procedure will insure that the alignment will always be well below these tolerance values.

Using PowerLine Level Vial

Each PowerLine laser emitter has a 40 arc minute vial mounted to the top of the unit. Use it to check levelness of pulleys, sprockets, conveyors, etc. as needed. The vial is preset level in the factory so it runs true with bottom magnetic surface of the housing.

Maintenance:

The PowerLine is weather-resistant, rugged, and durable. The front optic window is coated with a high performance film. Clean lens with a lint free cloth or swab using a premium glass cleaner solution. Clean housing and targets with damp cloth only. Magnets are nickel coated to prevent rusting.

Calibration:

The PowerLine laser is factory calibrated so that the laser line is emitted exactly 0.312" above the bottom magnetic surface. No field calibration is required.

Battery Replacement:

To replace discharged batteries, unscrew and remove the 2 Duracell size "AAA" alkaline batteries and install new ones. The negative ends go in first. Spare batteries are included in the case at initial shipment.

Technical Specifications: Model 80 Pulley Alignment System

Pulley Alignment Tool:	1 $\frac{3}{4}$ " x 6 $\frac{3}{4}$ " x $\frac{5}{8}$ "
Target Dimensions:	1 $\frac{1}{4}$ " diameter x 1" length
Weight of Laser Tool:	14 oz.
Vial:	40 Arc min.
Beam Spread:	60 inches @ 60 inches
Line Width:	$\frac{1}{16}$ " @ 30 inches
Housing / Target:	High Grade Anodized Aluminum
Targets:	Qty. 3- adjustable over $\frac{5}{8}$ "
Magnets:	Nickel Plated Rare Earth
Power:	Qty. 2- Size "AAA" Batteries (10 hrs.)
Accuracy:	+/- $\frac{1}{16}$ "@10 feet
Pulley Size Range:	All
Operating Distance:	50 feet
Case Dimensions:	10- $\frac{5}{8}$ x 7x 3 inches
IP Rated:	67

How to Operate "KRIKIT" V-belt Tension Gauge

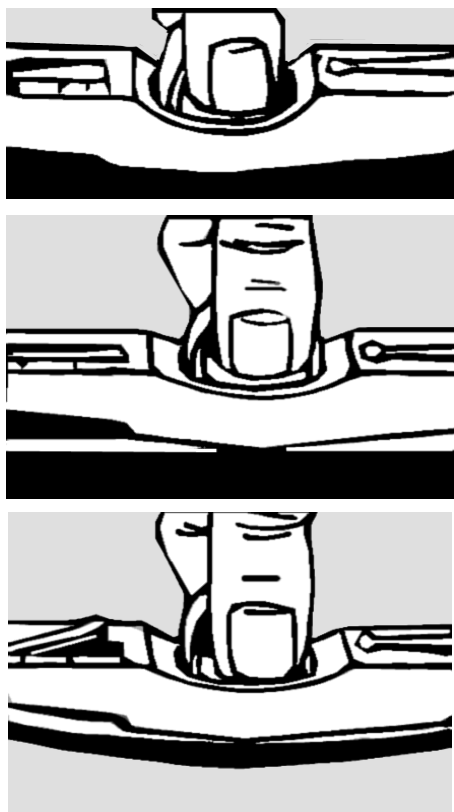
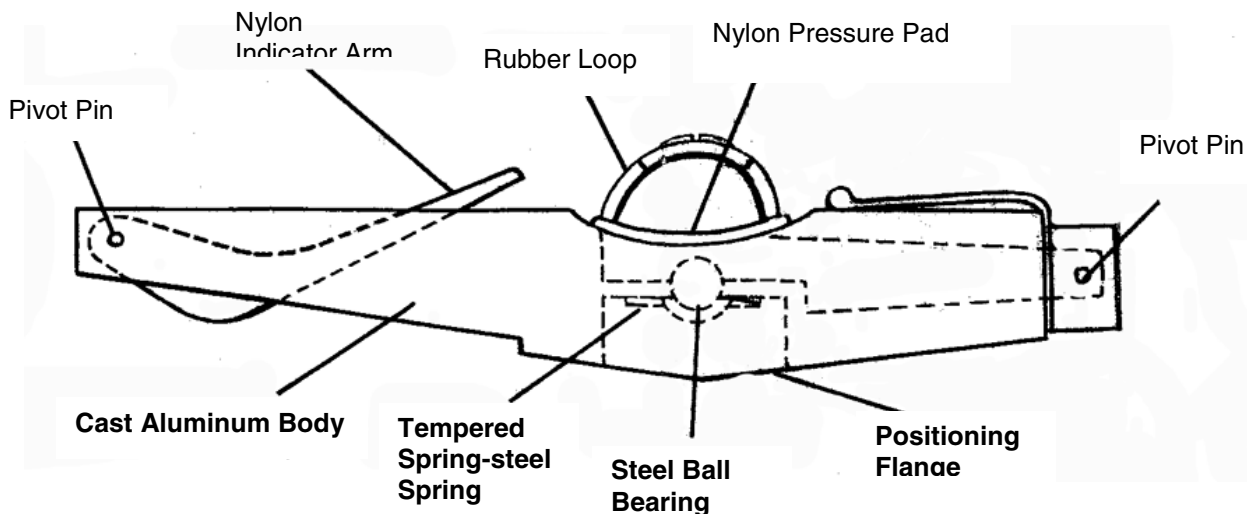

Position the Gauge Correctly

Hold the gauge by the rubber loop between the thumb and index finger.

Position the gauge in the center of the belt between the two pulleys.

Make sure the indicating arm is below the scale on top of the gauge before making a reading

Press for Reading

Very slowly push on the pressure pad at a right angle to the top of the belt surface until you hear (or feel) the click release of the tension spring under the pad.

As soon as the spring "clicks" the indicator arm shows the correct reading for that belt

How to Read Belt Tension

The correct tension is read by observing where the black indicator arm crosses the numbered scale on the top of the gauge.

